

ASSEMBLY INSTRUCTIONS FOR #67970

IMPORTANT

TURN OFF THE POWER AT THE MAIN FUSE OR CIRCUIT BREAKER BOX BEFORE STARTING INSTALLATION

CAREFULLY UNPACK AND IDENTIFY ALL PARTS BEFORE ASSEMBLY. BULBS ARE NOT INCLUDED

THIS FIXTURE WEIGHS OVER 50 LBS.
NEC:314.27B, A luminaire that weighs more then 23kg (50lb) shall be supported independently of the outlet box unless the outlet box is listed AND MARKED for the MAXIMUM weight supported.

THIS IS A TWO PERSON JOB

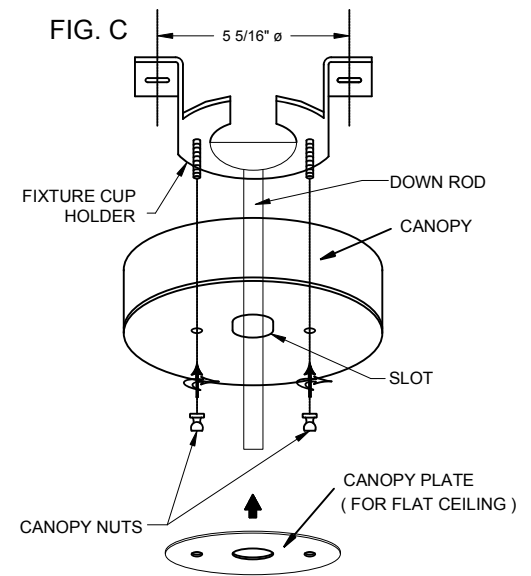
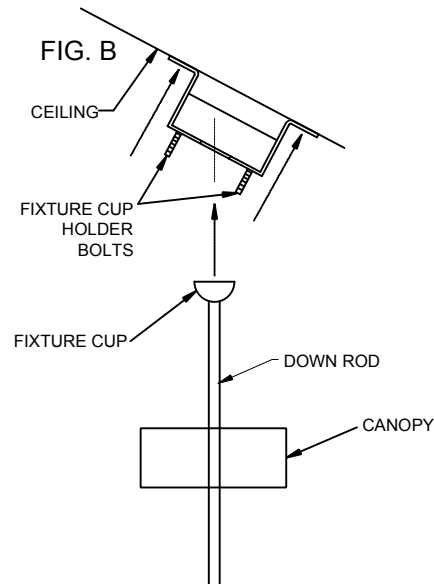
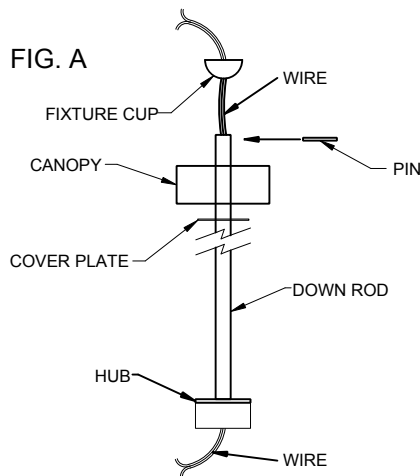

- 1) ATTACH FIXTURE CUP HOLDER TO A SECURE LOCATION USING FASTENERS SUPPLIED BY OTHERS. FIG. B
- 2) IF SHORTER STEM LENGTH IS DESIRED, REMOVE WIRE & SAFETY CABLE FROM DOWN ROD, CUT ROD TO SHORTER LENGTH, DRILL NEW HOLE FOR PIN.
- 3) FEED WIRES & SAFETY CABLE THROUGH DOWNROD.

FOR SLANTED CEILING

- 4) SLIDE CANOPY ONTO DOWNROD FIG. A
- 5) PLACE FIXTURE CUP ONTO DOWNROD. INSERT PIN INTO END OF DOWNROD MAKING SURE PIN IS CENTERED TO ENSURE PROPER SEATING INTO FIXTURE CUP. FIG. A
- 6) HANG STEM & HUB ASSEMBLY BY SLIDING FIXTURE CUP THROUGH SLOT IN FIXTURE CUP HOLDER. FIG. B
- 7) SECURE SAFETY CABLE TO SECURE LOCATION.
- 8) WIRE AS PER LOCAL ELECTRICAL CODES.
- 9) ATTACH CANOPY FASTENING WITH CANOPY NUTS PROVIDED. FIG. C

FOR FLAT CEILING

- 4) SLIDE COVER PLATE THEN CANOPY OVER DOWNROD. FIG. A
- 5) PLACE FIXTURE CUP ONTO DOWNROD. INSERT PIN INTO END OF DOWNROD MAKING SURE PIN IS CENTERED TO ENSURE PROPER SEATING INTO FIXTURE CUP. FIG. A
- 6) HANG STEM & HUB ASSEMBLY BY SLIDING FIXTURE CUP THROUGH SLOT IN FIXTURE CUP HOLDER. FIG. B
- 7) SECURE SAFETY CABLE TO SECURE LOCATION.
- 8) WIRE AS PER LOCAL ELECTRICAL CODES.
- 9) ATTACH CANOPY AND COVER PLATE, FASTENING WITH CANOPY NUTS PROVIDED. FIG. C.

STEP 1

SECURE HUB & STEM ASSEMBLY

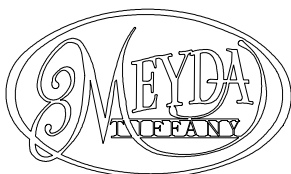

"A Commitment to Excellence in Lighting and Service"
CALL OUR CUSTOMER SERVICE DEPARTMENT AT 1-800-222-4009
MONDAY - FRIDAY 8:00a.m - 6:00p.m ET
visit us on the web at www.meyda.com

ASSEMBLY INSTRUCTIONS FOR #67970

IMPORTANT
 TURN OFF THE POWER AT THE MAIN FUSE OR CIRCUIT BREAKER BOX BEFORE STARTING INSTALLATION

CAREFULLY UNPACK AND IDENTIFY ALL PARTS BEFORE ASSEMBLY. BULBS ARE NOT INCLUDED

THIS FIXTURE WEIGHS OVER 50 LBS. NEC:314.27B, A luminaire that weighs more then 23kg (50lb) shall be supported independently of the outlet box unless the outlet box is listed AND MARKED for the MAXIMUM weight supported.

THIS IS A TWO PERSON JOB

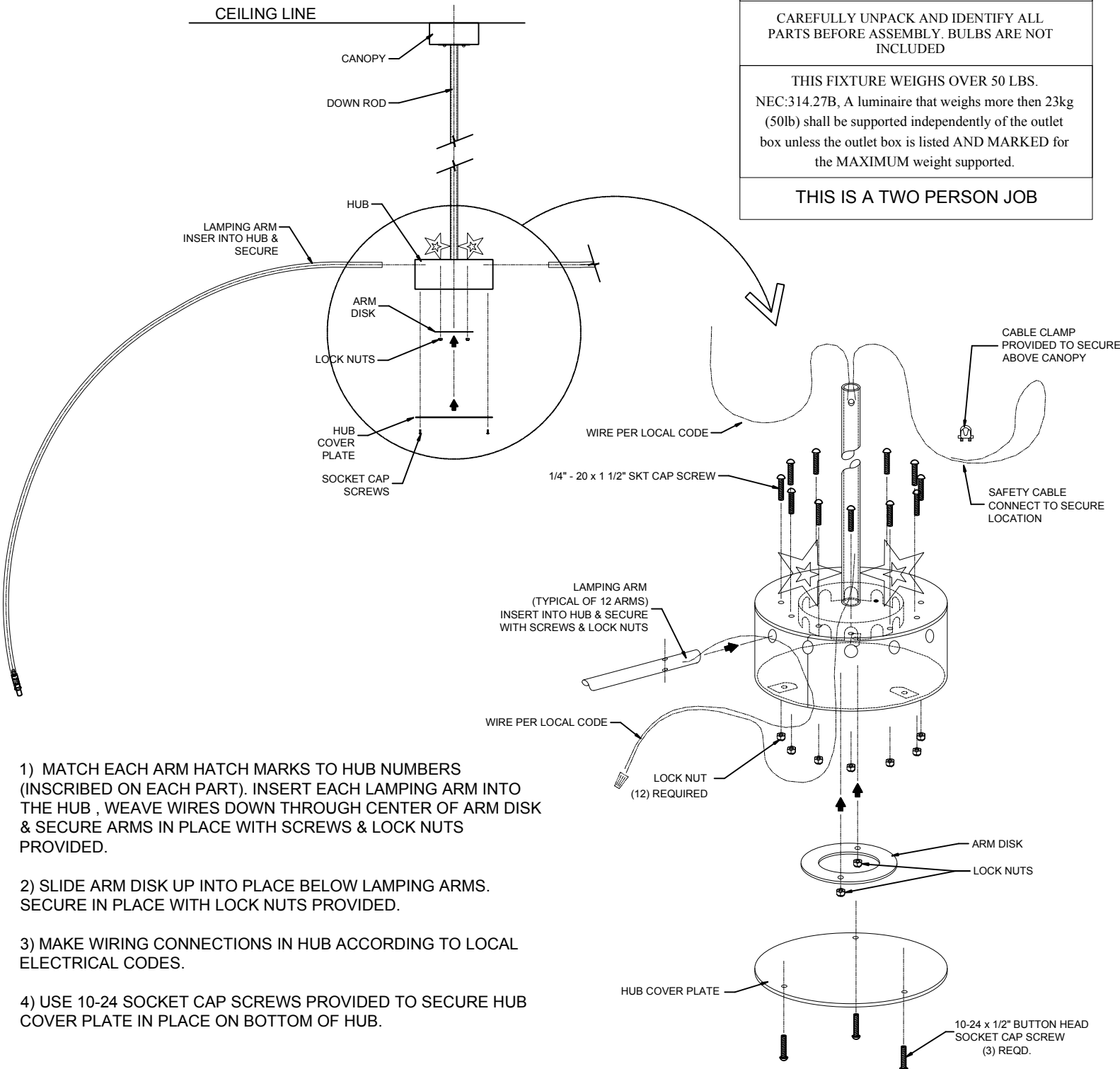

- 1) MATCH EACH ARM HATCH MARKS TO HUB NUMBERS (INSCRIBED ON EACH PART). INSERT EACH LAMPING ARM INTO THE HUB , WEAVE WIRES DOWN THROUGH CENTER OF ARM DISK & SECURE ARMS IN PLACE WITH SCREWS & LOCK NUTS PROVIDED.
- 2) SLIDE ARM DISK UP INTO PLACE BELOW LAMPING ARMS. SECURE IN PLACE WITH LOCK NUTS PROVIDED.
- 3) MAKE WIRING CONNECTIONS IN HUB ACCORDING TO LOCAL ELECTRICAL CODES.
- 4) USE 10-24 SOCKET CAP SCREWS PROVIDED TO SECURE HUB COVER PLATE IN PLACE ON BOTTOM OF HUB.

STEM & HUB ASSEMBLY

(EXPLODED VIEW)

STEP 2

INSTALL & SECURE LAMPING ARMS

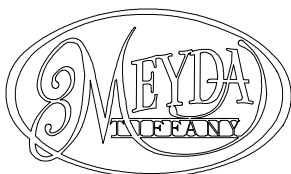

"A Commitment to Excellence in Lighting and Service"

CALL OUR CUSTOMER SERVICE DEPARTMENT AT 1-800-222-4009

MONDAY - FRIDAY 8:00a.m - 6:00p.m ET

visit us on the web at www.meyda.com