

# ASSEMBLY INSTRUCTIONS FOR # 155397

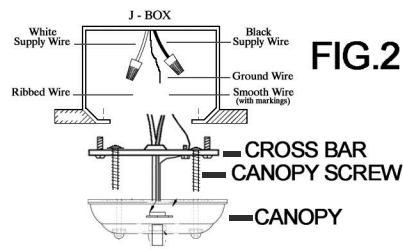
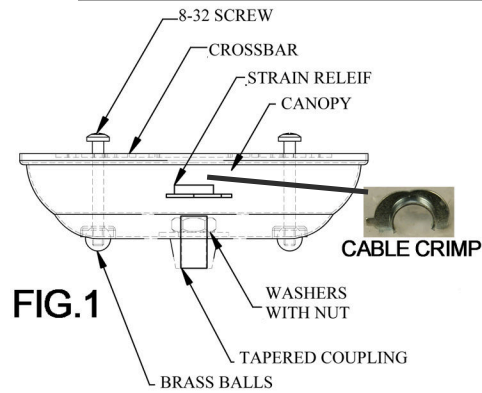

FIG.2

**IMPORTANT**  
TURN OFF THE POWER AT THE MAIN FUSE OR CIRCUIT BREAKER BOX BEFORE STARTING INSTALLATION

CAREFULLY UNPACK AND IDENTIFY ALL PARTS BEFORE ASSEMBLY. BULBS ARE NOT INCLUDED

- 1) READ ALL INSTRUCTIONS
- 2) ATTACH CROSS BAR TO J-BOX, THERE SHOULD BE TWO CANOPY SCREWS (FIG.2) POINTING DOWN TOWARDS THE FIXTURE.
- 3) DETERMINE THE OVERALL HEIGHT OF THE FIXTURE AND THEN APPLY CABLE CRIMP ABOVE THE CANOPY. (FIG.1)
- 4) LIFT FIXTURE INTO PLACE AND CONNECT ALL ELECTRICAL WIRES AS PER LOCAL CODES.
- 5) SLIDE CANOPY INTO PLACE AND SECURE WITH CANOPY NUTS (FIG.1)
- 6) WITH YOUR HANGAR BOLTS PROVIDED, SECURE THE CEILING LOOPS TO THE CEILING, ATTACH SUPPORT CABLES TO THE LOOPS AND CLAMP CABLES. (FIG.3 AND 4)
- 7) RUN THE CABLES THROUGH THE CABLE GRIPPERS BY UNSCREWING JUST A LITTLE (NOT ALL THE WAY) THE SCREW SLEEVE AT THE TOP OF GRIPPER. PUSH DOWN ON SLEEVE THIS WILL ALLOW THE CABLE TO PASS THROUGH, LET GO AND IT WILL GRIP. WHEN YOU HAVE IT AT THE DESIRED LENGTH SCREW SLEEVE BACK DOWN. (FIG.5)
- 8) YOU MAY CUT CABLE ONLY WHEN YOU ARE SURE OF THE LENGTH.
- 9) BULB YOUR FIXTURE, TURN ON AND ENJOY YOUR NEW FIXTURE.

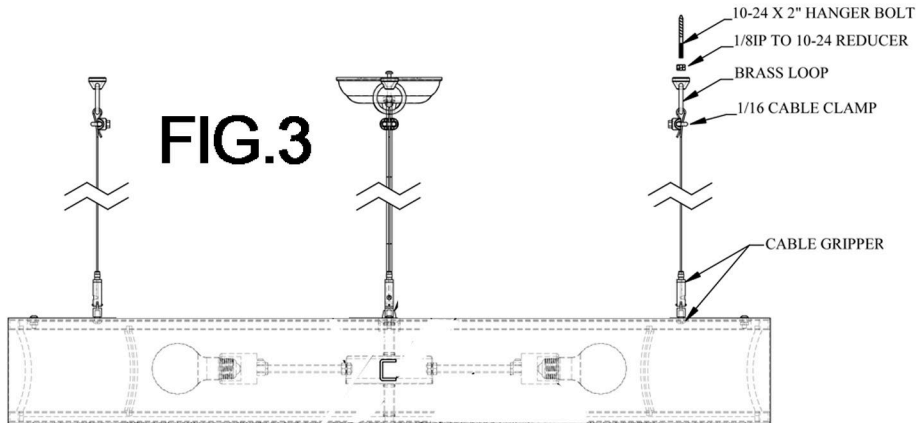

FIG.3



FIG.4



FIG.5



*"A Commitment to Excellence in Lighting and Service"*

CALL OUR CUSTOMER SERVICE DEPARTMENT AT 1-800-222-4009

MONDAY - FRIDAY 8:00 a.m. - 6:00 p.m. ET

visit us on the web at [www.meyda.com](http://www.meyda.com)