

CUSTOMER NAME:

CUSTOMER #:

CUSTOMER PROPOSAL/CUT SHEET



"A Commitment to Excellence in Lighting and Service"

CALL OUR CUSTOMER SERVICE DEPARTMENT AT 1-800-222-4009

MONDAY - FRIDAY 8:00 a.m. - 6:00 p.m. ET

visit us on the web at www.meyda.com

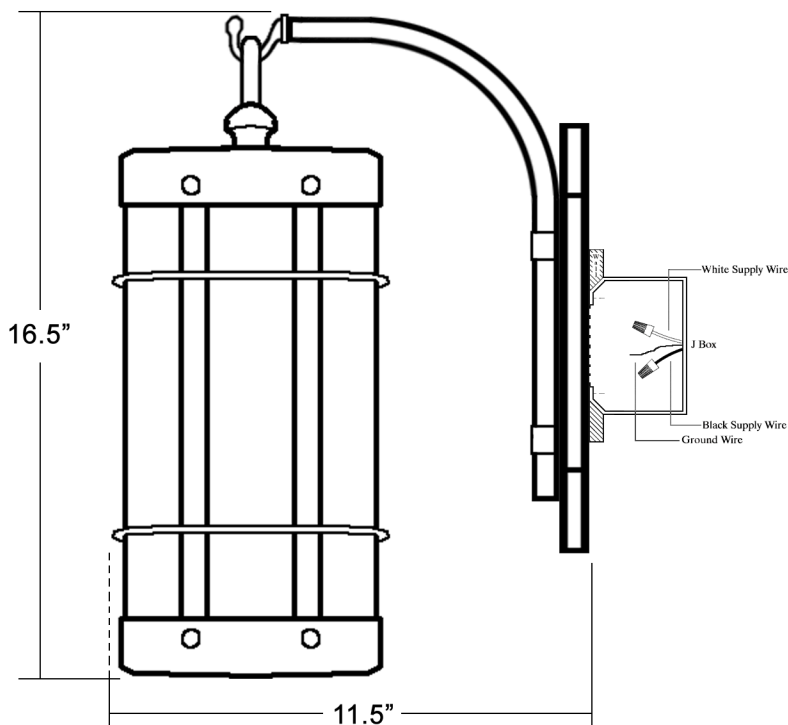
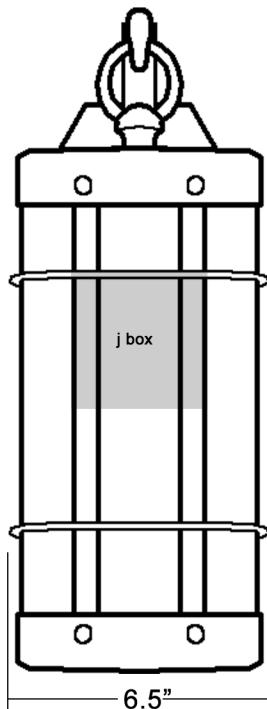

© MEYDA TIFFANY, INC. © DESIGN COPYRIGHT, MEYDA TIFFANY, INC. ALL RIGHTS RESERVED, NO UNAUTHORIZED DUPLICATION



ITEM# 129094	BULB# 1	LOCATION
DESIGN# 36404-5	TYPE MEDIUM BASE	
FIXTURE TYPE WALL SCONCE	WATT 100	DIMENSIONS/NOTES
LENS/GLASS COLOR CUSTOMER WILL SUPPLY	VOLTAGE 120	
FINISH CRAFTSMAN BROWN	MATERIAL BRASS	WEIGHT