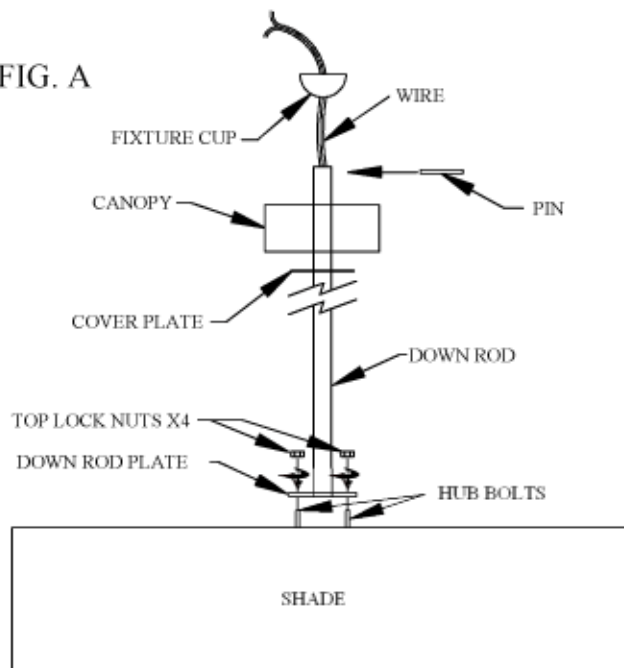
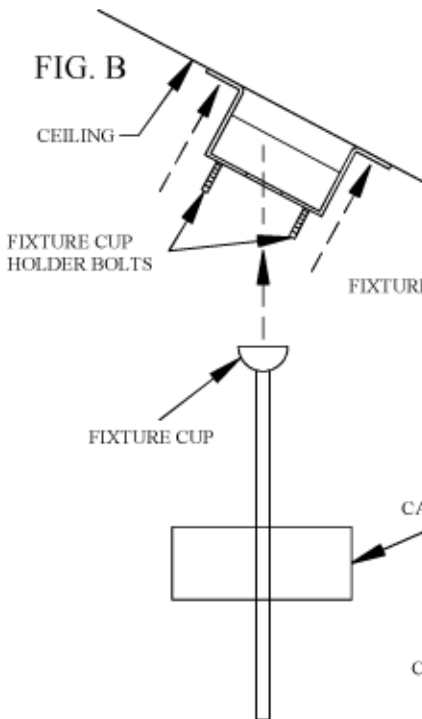
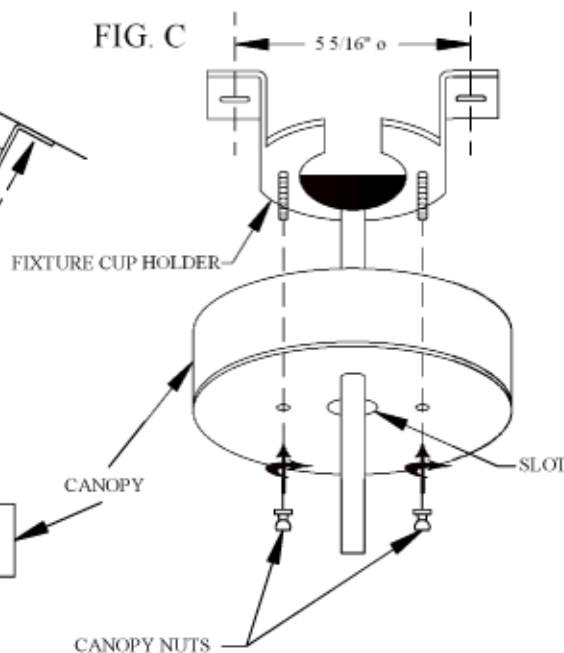

FIG. A

FIG. B

FIG. C

IMPORTANT

TURN OFF THE POWER AT THE MAIN FUSE OR CIRCUIT BREAKER BOX BEFORE STARTING INSTALLATION

CAREFULLY UNPACK AND IDENTIFY ALL PARTS BEFORE ASSEMBLY. BULBS ARE NOT INCLUDED

THIS FIXTURE WEIGHS OVER 50 LBS.
 NEC:314.27B, A luminaire that weighs more than 23kg (50lb) shall be supported independently of the outlet box unless the outlet box is listed AND MARKED for the MAXIMUM weight supported.

THIS IS A TWO PERSON JOB

- 1.) ATTACH FIXTURE CUP HOLDER TO A SECURE LOCATION USING FASTENERS SUPPLIED BY OTHERS. FIG. B
- 2.) CUT DOWN ROD TO DETERMINED LENGTH BY MEASURING UP FROM DOWN ROD PLATE.
- 3.) REDRILL A 1/4" HOLE 1/4" DOWN FROM CUT EDGE OF DOWN ROD.
- 2.) FEED WIRES THROUGH DOWN ROD. PLACE DOWN ROD PLATE ONTO HUB BOLTS (4) AND TIGHTEN WITH LOCK NUTS PROVIDED FIG. A.

FOR SLANTED CEILING

- 3.) SLIDE CANOPY ONTO DOWN ROD FIG. A
- 4.) PLACE FIXTURE CUP ONTO DOWN ROD. INSERT PIN INTO END OF DOWN ROD MAKING SURE PIN IS CENTERED TO ENSURE PROPER SEATING INTO FIXTURE CUP. FIG. A
- 5.) HANG FIXTURE BY SLIDING FIXTURE CUP THROUGH SLOT IN FIXTURE CUP HOLDER. FIG. B
- 6.) WIRE AS PER LOCAL ELECTRICAL CODES.
- 7.) ATTACH CANOPY FASTENING WITH CANOPY NUTS PROVIDED. FIG. C

FOR FLAT CEILING

- 8.) FEED WIRES THROUGH DOWN ROD. PLACE DOWN ROD PLATE ONTO HUB BOLTS (4) AND TIGHTEN WITH LOCK NUTS PROVIDED FIG. A.)
- 9.) SLIDE COVER PLATE THEN CANOPY OVER DOWN ROD. FIG. A
- 10.) PLACE FIXTURE CUP ONTO DOWN ROD. INSERT PIN INTO END OF DOWN ROD MAKING SURE PIN IS CENTERED TO ENSURE PROPER SEATING INTO FIXTURE CUP. FIG. A
- 11.) HANG FIXTURE BY SLIDING FIXTURE CUP THROUGH SLOT IN FIXTURE CUP HOLDER. FIG. B
- 12.) WIRE AS PER LOCAL ELECTRICAL CODES.
- 13.) ATTACH CANOPY AND COVER PLATE, FASTENING WITH CANOPY NUTS PROVIDED. FIG. C.



"A Commitment to Excellence in Lighting and Service"

CALL OUR CUSTOMER SERVICE DEPARTMENT AT 1-800-222-4009

MONDAY - FRIDAY 8:00a.m - 6:00p.m ET

visit us on the web at www.meyda.com



SPECIFICATIONS

"A Commitment to Excellence in Lighting and Service"

CALL OUR CUSTOMER SERVICE DEPARTMENT AT 1-800-222-4009

MONDAY - FRIDAY 8:00a.m - 6:00p.m ET

visit us on the web at www.meyda.com



*DIMENSIONS AND DETAILS DURING PRODUCTION ARE SUBJECT TO MODIFICATION FOR MECHANICAL/ENGINEERING PURPOSES TO ENSURE THE SAFE OPERATION AND LONGEVITY OF PRODUCT.

© MEYDA TIFFANY INC © DESIGN COPYRIGHT, MEYDA TIFFANY, INC. ALL RIGHTS RESERVED, NO UNAUTHORIZED DUPLICATION



ITEM#110039	BULB# 8/8	LOCATION:	
DESIGN#1-0371202261-196	TYPE: MR16/MEDIUM BASE		Date:
FIXTURE TYPE: CHANDEL-AIR	WATT: 50/100	DIMENSIONS/NOTES:	
LENS COLOR: CHROME DIAMOND PLATE	VOLTAGE: 120	APPROVAL	
FINISH: BLACK, CHROME	MATERIAL: STEEL, ALUMINIUM	WEIGHT: 70 LBS	

Fan Specifications

Integrating the best of both worlds, Chanlel-Air incorporates custom lighting design with fan technologies. Form and function presented beautifully. Designed for ceilings of any pitch or height. Dimming capabilities included. Fan specifications listed below.

Features

- Standard, 3 Speed Reversible motor
- 2" and 6" Down rods (included)
- 30 year limited warranty
- Custom 29" Piccolo Blades Sold Separately
- Light Kit Adaptable (optional)
- Universal Control Adaptable (UC-2000) (Optional)
- Great for Small Spaces

* Compare, 36" to 48" ceiling fans have air-flow efficiencies ranging from approximately 71 to 86 cubic feet per minute per watt at high speed

Specs

Blade Sweep	29"
Number of Blades	5
Blade Pitch	25"
Motor Size (MM)	153 x 8
AMPS (HI Speed)	0.4
Watts (HI Speed)	46
RPM (HI-MED-LOW)	200-120-55
Shipping Wt. (lbs.)	13.71
CU. FT in Carton	1
Airflow*	2,267 (Cubic Feet Per Minute)
Airflow Efficiency*	50 (Cubic Feet Per Minute Per Watt)

Ceiling Drop Dimensions

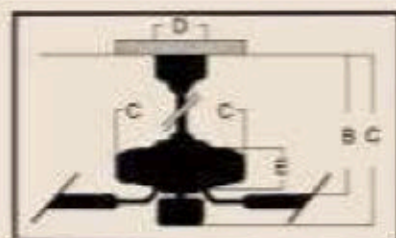

- A: 2" DR - 10.25" B: 2" DR - 8.0"
- A: 6" DR - 14.25" B: 6" DR - 12.0"
- C: 9.0" D: 5.875"
- E: 3.25"
- DR: Down rod

Available Finishes



AW-Antique White



BN-Brushed Nickel



OB-Oiled Bronze



W-White

Blade Options

Model Specific: Available in AW (Antique White), BN (Brushed Nickel), DOK (Dark Oak), LOK (Light Oak), OB (Oiled Bronze) and W (White)

Remotes (optional)

Universal Remote Control System with Receiver



UC-2000.W

*remote control units may vary